

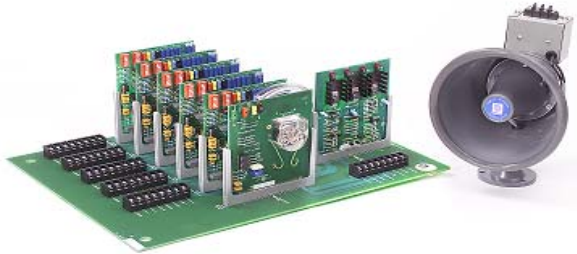

## **MillMinder** Audio Signal Converter

## TECHNICAL SPECIFICATION



## Want to control grinding mill feed, Automatically?

The *MillMinder* Audio Signal Converter listens to the sound levels generated by the impact inside the grinding mill and provides the operator with an output signal which allows automatic material feed control to the mill.

Prior to the introduction of the Audio Signal Converter, mill operators walked beside the mill and listened to the grinding noises. From this they were able to determine the grinding conditions within the mill and decide whether or not to increase or decrease the feed rate.

This was possible because the noise generated in the mill by the impact action of the grinding media (balls or rods) is an inverse function of the quantity of material present to cushion its impact and absorb its energy. Consequently, as a mill is progressively filled, the noise level within it is progressively decreased; conversely, as a mill is progressively emptied, the noise level is progressively increased.

A material which is hard to grind will have a longer retention time and cause an increase in the amount of material charge. Conversely, easier to grind materials will have a shorter retention time and cause a decrease in the material charge.

This early method of determining mill conditions, though well founded, was often inaccurate and manpower intensive. By utilization of more suitable sound sensors, excellent grinding process control is achieved.

The sound emanating from the grinding mill consists basically of frequencies in the 100 - 100,000 Hz range. A rugged microphone assembly detects this sound at the point of impact of the mill charge. The Microphone/Sound Sensor transmits its signal to an amplifier/convertor where the amplitude at a selected frequency is amplified and converted to a DC voltage suitable for use by plant operators.

### **Benefits:**

- Improve the uniformity of the grind
- Reduce operator supervision
- Reduce labor costs
- Reduce mill liner, ball and rod wear per unit of product.
- Decrease power costs per unit of product
- Improve productivity
- Reduce Overgrinding
- Eliminate plugging and loss of production

### **Features:**

- Up to five (5) inputs from various monitoring points on the mill
- Discrete 4-20 mA outputs for each point being monitored
- Simple to install
- Ideal for dry and wet grinding processes
- Greater control over varying conditions in your grinding mill due to changes in specific gravity or hardness
- Standard 4-20 mA recorder outputs negative common bus that can be connected to computer common input bus without isolators and/or convertors.

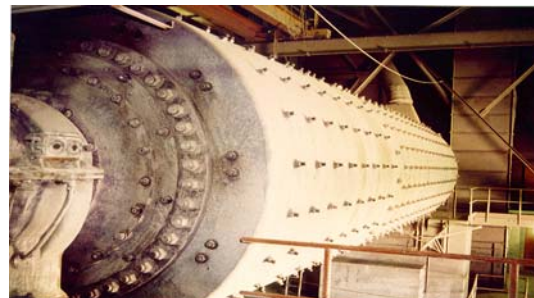

## DRAWINGS

### ENCLOSURE DIMENSIONS

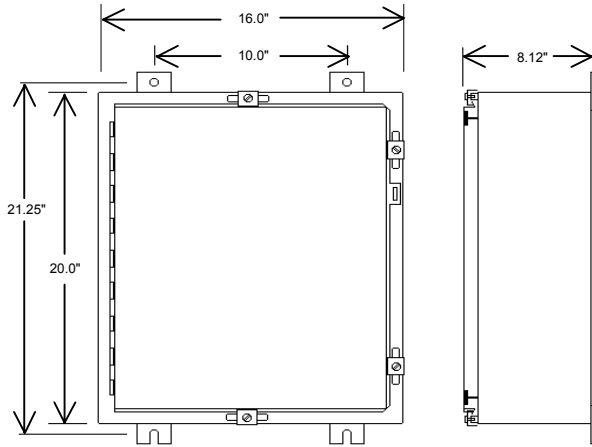

### MILLPHONE DIMENSIONS

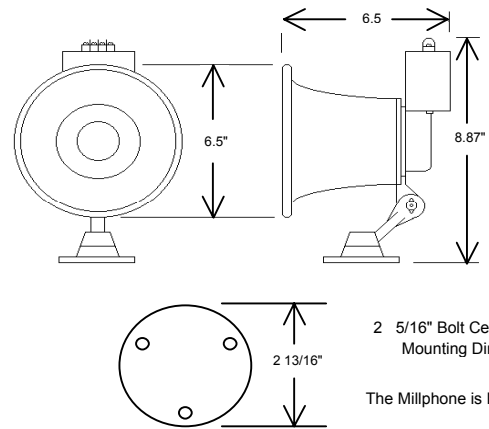

2 5/16" Bolt Center Distance Mounting Dimensions

The Millphone is NEMA 1 rated.

## INTERCONNECTION

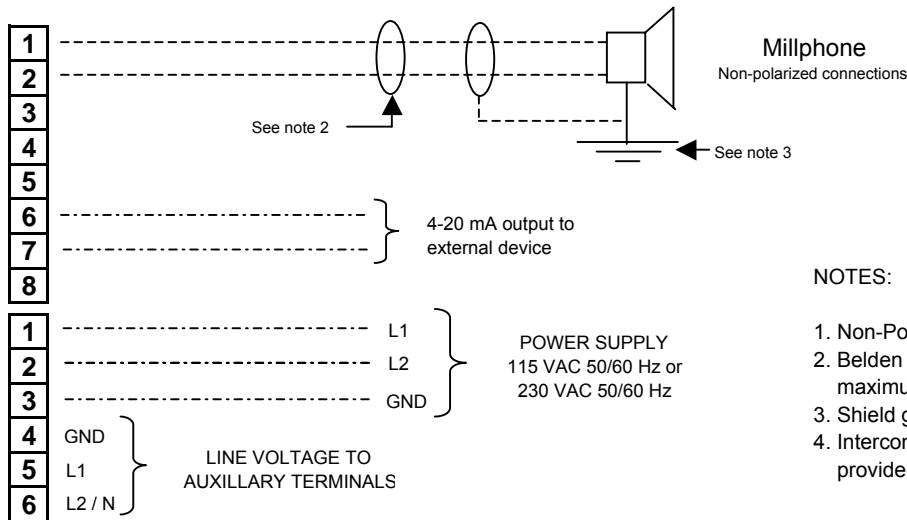

## TYPICAL EQUIPMENT INSTALLATION

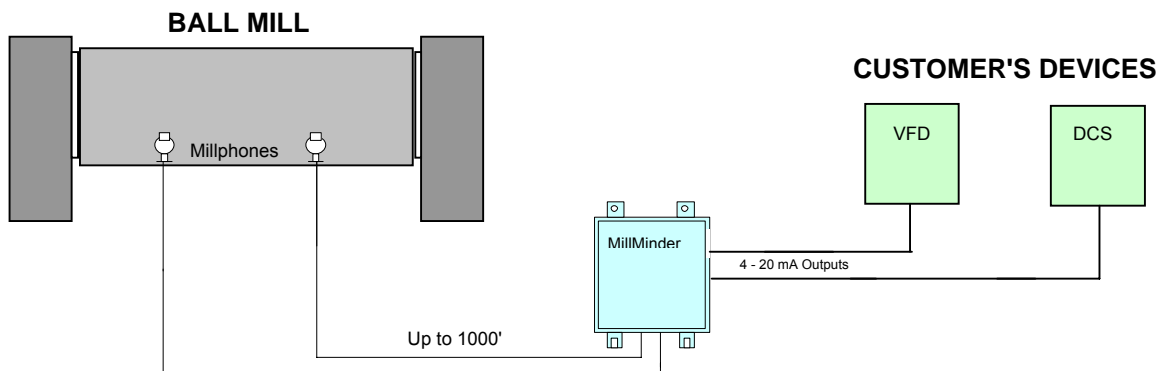

## TECHNICAL SPECIFICATIONS

### Inputs:

- Millphone Microphone Assembly
- 0 - 1 through 0 - 10 VDC
- 4 - 20 mA field calibrateable

### Outputs:

- 4 - 20 mA standard into 750 ohms.  
Up to 5 discrete outputs. Isolated from all other signals.
- Auxillary power output

### Power Requirements:

- 115 VAC, 50/60 Hz, 20 VA
- 230 VAC, 50/60 Hz, 20 VA

### Dimensions:

- Module Rack - Open Style  
17" High (432mm) x  
13" Wide (330mm) x  
6.25" Deep (159mm),  
15" (381mm) x 11" (279mm)  
mounting centers.
- Nema 4 Enclosure  
20" High (508mm) x  
16" Wide (406mm) x  
8.12" Deep (206mm),  
21.25" (540mm) x 10" (254mm)  
mounting centers

## COMMON APPLICATIONS AND INDUSTRIES SERVED

### INDUSTRIES SERVED

Cement, Mining, Power, Aluminum, Silica Sand, Trona, etc.

Cement Finish Mill  
Dual Compartment

Cement Raw Mill  
Dual Compartment

Cascade Type Mill  
Single Compartment

Coal Mill, Air Swept, Single Discharge  
Dual Compartment

Cement, Rock Mill  
Single Compartment

Aerofall Mill  
Single Compartment

Regrind Mill  
Single Compartment

Center Discharge, Airswept  
Dual Compartment

## TYPICAL EQUIPMENT INSTALLATION

### MICROPHONE POSITIONING

The Microphone should be placed below the "TOE" of the charge and to within six (6) inches of the mill shell. As the distance away from the mill shell is increased, crosstalk will increase. The "TOE" usually occurs between the 4:00 and 5:30 o'clock position on the mill shell and usually emits the maximum sound intensity. The position is dependent upon the speed and charge volume of the mill. Sound reversals may be experienced if the Microphone is located too high.

The Microphone position along the length of the compartment is harder to establish. If the Microphone is too close to the trunion end or dividing screens, sound reversals and /or random signals may occur. As many rows as possible between bolts should be checked under minimum, maximum and average feed conditions to establish optimum positioning. Equipment manual provides radial and lateral positioning instructions.

## ORDERING INFORMATION

### *MillMinder* Audio Signal Convertor

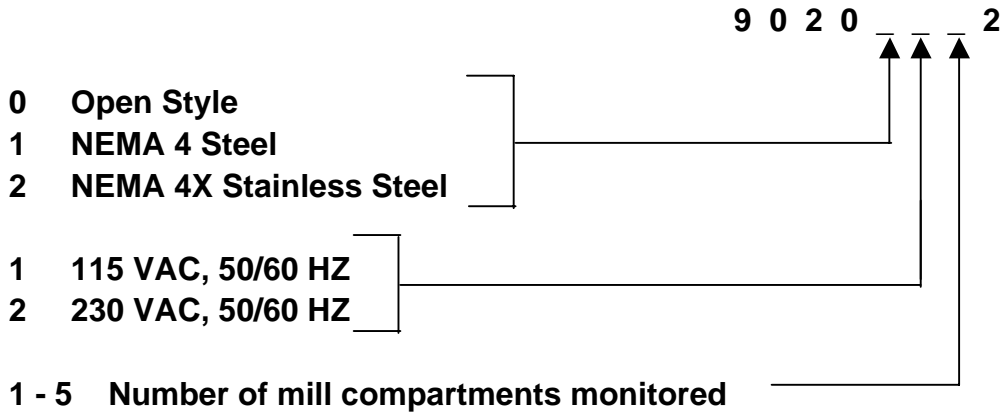

Equipment for each compartment being monitored comes with a Module Rack, a Voltage Regular card, a Meter card, a Sonic Sensor card, and a Millphone microphone assembly. The Module Rack will hold up to five Sonic Sensor cards.

## SPARE PARTS

MR-50 Module Rack, 115 VAC	51009011
MR-50 Module Rack, 230 VAC	51009012
VR-50 Voltage Regulator Card	51008991
MC-50 Meter Card	51009001
SS-50 Sonic Sensor Card	51008971
 Millphone Microphone Assembly	 61001011
 Fuse, Box of 5, 1/8 Amp (for 230 VAC)	 22550060
Fuse, Box of 5, 1/4 Amp (for 115 VAC)	22550070
Fuse, Box of 5, 5 Amp (for 115 & 230 VAC)	22550095
Extra Manual (MI-1)	51003001
Belden Cable, 8760	06700095

## COMMERCIAL TERMS AND CONDITIONS

- Net 30 Days with approved credit
- FOB Factory, Watauga, Texas, USA
- All freight, insurance, taxes, duty, brokerage and other charges occurring as the result of this transaction will be paid by the purchaser.
- Shipment will normally occur 1 - 2 weeks after release for shipment
- Start-up assistance and training is available.

- Warranty: Westec warrants equipment of its own manufacture to be free of defects caused by defective workmanship or faulty parts. Westec will, at its option, exchange or repair those defective parts free of charge for a period of 12 months from shipment date.
- Governing Terms: Any contract or sale made hereunder shall be governed by the laws of the State of Texas, USA.

Your Representative:



10537 Bradshaw Drive  
 Fort Worth, Texas 76108  
 Tel: 682-336-1259  
 e-mail: westecinstrumentation@gmail.com  
 www.westecinstrumentationllc.com