



NCT-2

NON-CONTACTING TACHOMETER
Instruction Manual

IM-3

September 2003

USA: 10537 Bradshaw Dr. Fort Worth, TX 76108

Tel/682-336-1259

E-mail: westecinstrumentation@gmail.com

CATALOG NUMBERING SYSTEM

NON-CONTACTING TACHOMETER

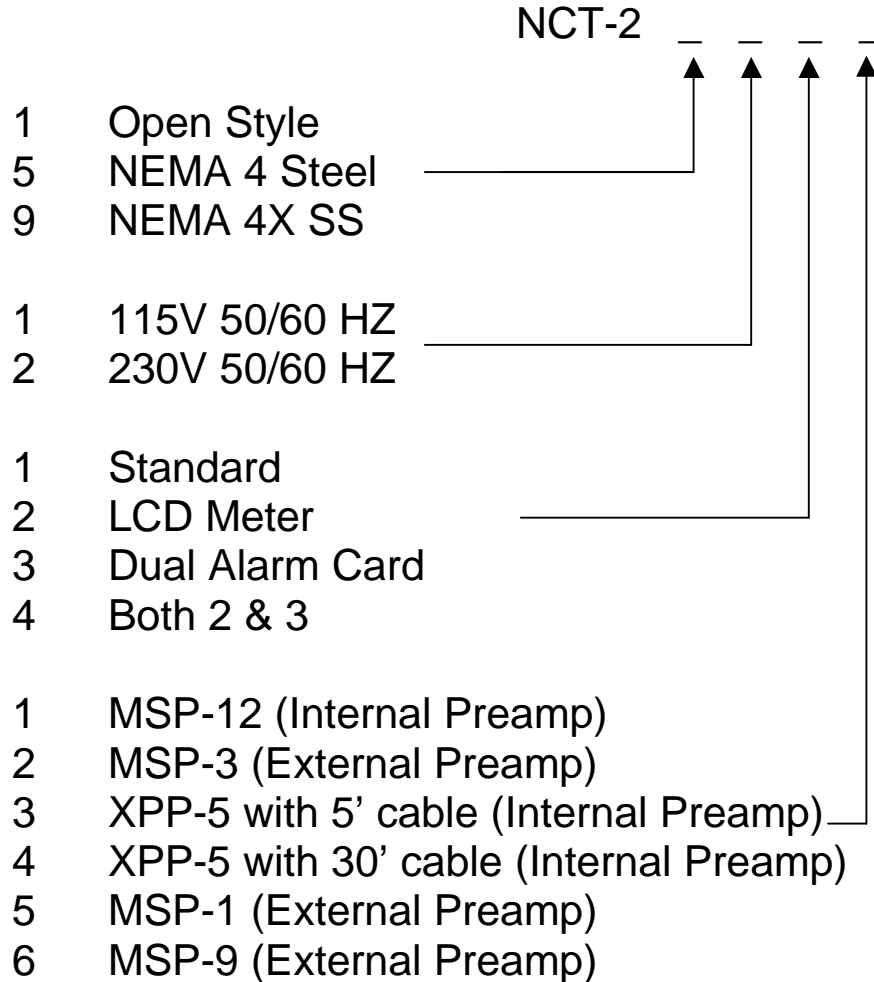

SPECIFICATIONS

Power Supply	- 115 VAC, 50 / 60 HZ, 40 VA (with maximum 3 dual alarm modules) - 230 VAC, 50 / 60 HZ, 40 VA (with maximum 3 dual alarm modules) - $\pm 10\%$ of rated voltage
Accuracy	- dependent on calibration standards, normal $\pm 0.5\%$ overall of full scale
Repeatability	- $\pm 0.1\%$ of full scale
Linearity	- $\pm 0.1\%$ of full scale from 4% to 100%
Temp. Coefficient	- 0.3% per °F (0.05% per °C)
Span	- full scale span is adjustable from 8 to 7200 PPM for 100%. minimum output is 4% of full scale or 0 at loss of probe pulses.
Damping	- 0 to 10 seconds
Outputs	- 4 to 20 mA into 750 ohms and 0 to 10V (5mA max.) for 0 to 100%. Any one of four output terminals may be grounded. - optional: Dual Satellite Alarm Module consisting of 2 DPDT relays, for one Near and one Far setpoint per module. - Deadband is standard 2% of full scale - Contact ratings: 10A at 115 VAC, ½ HPat 230 VAC

EQUIPMENT	AMBIENT TEMPERATURE RANGE	APPROX. WT.
Main Amplifier, Open	- 40°F to 140°F (- 40°C to 60°C)	1.5 lbs
Main Amplifier, NEMA 4	- 40°F to 140°F (- 40°C to 60°C)	11 lbs
Main Amplifier, NEMA 4X SS	- 40°F to 140°F (- 40°C to 60°C)	11 lbs
Main Amplifier, NEMA 4 Large	- 40°F to 140°F (- 40°C to 60°C)	22 lbs
Main Amplifier, NEMA 4X SS Large	- 40°F to 140°F (- 40°C to 60°C)	22 lbs
RMA in Aluminum Enclosure	- 40°F to 140°F (- 40°C to 60°C)	5 lbs
RMA in NEMA 4 Painted Enclosure	- 40°F to 140°F (- 40°C to 60°C)	5 lbs
RMA in NEMA 4X SS Enclosure	- 40°F to 140°F (- 40°C to 60°C)	5 lbs
MSP-12	- 40°F to 140°F (- 40°C to 60°C)	3 lbs
MSP-3	- 60°F to 500°F (- 50°C to 260°C)	3 lbs
XPP-5 with 5 feet cable	- 40°F to 140°F (- 40°C to 60°C)	3 lbs
XPP-5 with 30 feet cable	- 40°F to 140°F (- 40°C to 60°C)	6 lbs
MSP-1	- 60°F to 180°F (- 50°C to 80°C)	1 lbs
MSP-9	- 60°F to 500°F (- 50°C to 260°C)	4 lbs
LCD Meter	- 5°F to 140°F (- 20°C to 60°C)	0.5 lbs

Calibration

FIELD

NCT-2

The NCT-2 is factory calibrated to 10 VDC for 7200 PPM so that there will not be an off scale reading when initially connected to the monitored device. The procedure below should be followed to calibrate the NCT-2.

1. Connect a voltmeter to terminals 5 (-) and 6 (+) of 2TB.
2. Run the monitored device at full speed or a known percentage of full speed.
3. Turn coarse span, SW1, down to a reading of greater than 2.5 volts. Then adjust fin span, P1, to 10 VDC is read on the meter (or a voltage equal to the known percentage of full speed identified in step 2, e.g. 80% of full speed equals 8 volts).
4. Press Cal. Zero, PB1, to zero the reading.
5. Connect a milliamp meter to terminals 7 (-) and 8 (+) of 2TB. A reading of 20 mA for 100% of full speed should be observed.
6. Pressing Cal. Zero, PB1 will give a reading of 4 mA. Do not disconnect the probe wiring to simulate zero.
7. Disconnect the meter from the NCT-2 and run the device at normal operating speed.

Dual Satellite Alarms

The dual-alarm module has two independent setpoint adjustments. To ensure fail-safe operation (relay de-energizes on alarm), always use the NEAR alarm as the HIGH alarm setpoint and the FAR alarm as the LOW alarm setpoint. Turning either alarm control in the clockwise direction causes that alarm to de-energize sooner (i.e. at a "less alarming" condition). The procedure below should be followed to make the alarm adjustments.

1. Turn both the NEAR (HIGH) potentiometer (P602) and the FAR (LOW) potentiometer (P601) controls fully counter-clockwise.
2. With the monitored device running at the required speed for the HIGH ALARM SETPOINT, slowly turn the NEAR control in the clockwise direction until the NEAR (HIGH) alarm relay de-energizes.
3. With the monitored device running at the required speed for the LOW ALARM SETPOINT, slowly turn the FAR control in the clockwise direction until the FAR (LOW) alarm relay de-energizes.

NOTE: If the system is highly damped, be certain that the output has reached a steady state before making the alarm adjustments.

LCD Meter

The LCD meter is factory calibrated to 0 – 100% but can be calibrated to any engineering unit requirements.

To calibrate the meter, the seals on P1 and P2 must be removed. The SPAN potentiometer, P1, sets the upper limit of the meter. The maximum reading being 1999. P2 is used to zero the meter. The decimal point is jumper selectable.

Calibration, continued

BENCH

NOTE: THE SEALS ON P3 AND P4 SHOULD NOT BE REMOVED UNLESS ABSOLUTELY NECESSARY.

Use a signal generator set at approximately 5 mV output, to simulate the full speed pulse rate of the device being monitored. Connect the signal generator to the Remote Mounted Pre-Amplifier then Pre-Amplifier to terminals 1, 2 and 3 of 1TB on the NCT-2.

Connect a milliamp meter to terminals 7 (-) and 8 (+) and a volt meter to terminals 5 (-) and 6 (+) on TB2 on the NCT-2.

Connect 115 VAC 50/60Hz to terminals 1 (L), 2 (N) and 3 (GR) on 2TB on the NCT-2.

The milliamp meter should read 20 mA and the voltmeter should read 10 VDC.

1. If both meter readings are correct the NCT-2 is properly calibrated. Move to step .
2. If a reading of $10\text{VDC} \pm 0.1\text{V}$ is not obtained, follow step 3 in the Field Calibration procedure.
3. If 10VDC cannot be reached, there is a problem with the circuitry and troubleshooting is required.
4. If the voltmeter reads 10 VDC but the milliamp meter does not read 20 mA, do the following:
 - A. Remove the seal from P4 (I max)
 - B. Adjust P4 until the milliamp meter reads $20\text{ mA} \pm 0.01\text{ mA}$.
 - C. If 20 mA cannot be reached, there is a problem with the circuitry and troubleshooting is required.
5. When the output readings are correct do the following:
 - A. Press PB1 (Zero Calibration) to simulate ZERO speed input. Do not switch off the signal generator or disconnect the leads to simulate ZERO.
 - B. The voltmeter should read 0 VDC
 - C. The milliamp meter should read 4 mA/
 - D. If the volt reading drops to 0 VDC and the mA reading drops BUT not to 4 mA, adjust P3 (I min)
 - E. Check 20 mA again and adjust if necessary
 - F. Reseal P3 and P4
6. If there is no change in reading, there may be a problem with the pushbutton.
7. The NCT-2 is now calibrated and ready to use.

Switch the signal generator off, the NCT-2 output signal will drop to less than 4% reading for a maximum of 50 seconds, then will go to ZERO volts and 4 mA.

OPERATING PRINCIPLES

NCT-2

The Non-contacting Tachometer NCT-2 is designed to provide an analog output proportional to the rate at which pulses are received from the Motion Sensing Probe (MSP) and Pre-Amp combination. The one outstanding feature of the NCT-2, compared to other general pulse to analog convertor type circuits, is its ability to monitor very low pulse rates and provide an analog output free of ripple but capable of responding almost instantaneously to a change in speed. The dynamic range of the NCT-2 is 7200 PPM (pulses per minute)(100%) to approximately 0.32 PPM (4%), depending upon span calibration.

THE PROBE

The Motion Sensing Probes work on the principle of Faraday's Laws of Electromagnetic Induction. That is to say, that when a ferromagnetic object enters permanent magnetic field, it distorts the flux causing it to cut the coil windings thereby generating a voltage. This voltage is proportional to the strength of the magnet and the number of wire turns in the coil (these being a constant in the probes) and the speed at which the ferrous target passes through the flux. The generated voltage is also inversely proportional to the square of the distance between the target and the probe. The relationship between the speed and gap of the standard probe is demonstrated by the chart on page 11.

THE PRE-AMPLIFIER (INTERNAL AND EXTERNAL)

The pre-amplifier is powered from the NCT-2 Main Amplifier, in series with R23A & R24, with a ± 24 VDC and a steady state current of approximately 10mA to 12mA. The millivolt signal, from the probe, is amplified then converted to a current pulse, which is superimposed on the steady state current supply, having current levels of 10mA Low to 40mA High. The Internal Preamp is integrally potted in the Probe. The External Preamp is mounted in an enclosure remote from the probe and the NCT-2.

THE MAIN AMPLIFIER

GENERAL THEORY OF OPERATION

The probe pulses are "signal" conditioned and fed to a PERIOD to ANALOG CONVERTOR whose output is proportional to the period of the pulses. The DC output of this circuitry is a voltage which is inversely proportional to speed. Therefore, to obtain the true speed, it is necessary to take the inverse of this DC voltage. To accomplish true speed, the output of the PERIOD to ANALOG CONVERTOR is fed to an analog divider, the output of which is proportional to speed.

CIRCUIT DESCRIPTION

Short Circuit Protection: Because of the possibility of the external wiring to the probe becoming shorted accidentally, short circuit protection has been provided to automatically limit the output current whenever the external resistance is 75 ohms or less. Under normal dynamic conditions, the voltage at terminal 1 is above 20V, therefore, Q4 conducts, Q3 is cut off and Q2 conducts and thus supplying normal working voltage current for the probe through Q2. Under short circuit conditions Q4 is reversed biased. Q3 conducts Q2 is cut-off. The +24V supply is

now applied to the output circuitry in series with the parallel combination of R16 & R17, limiting the short circuit output current to a low value of approximately 20mA. Output voltage at the terminals is kept to less than 2 volts.

Signal Conditioner: The current pulse from the pre-amplifier develops a square wave voltage across R23A and R24, having a value of 0.5V low and 2V high. This voltage is sensed by Q5. At the 2V level, Q5 conducts, developing a square wave output voltage across R15 and LED1 that alternates between 0V and approximately 22V. Since the period between pulses may vary anywhere from a few μS to several seconds, a programmable unijunction transistor Q1 functions to produce a single narrow output across R11 on the positive going leading edge of the waveform. Q1 is biased to fire when the applied input voltage reaches approximately 15V. The output is approximately 15V high and 40 μS wide. This signal is fed to the RAMP SAMPLE TIMER either directly or indirectly through the FREQUENCY DIVIDER.

Frequency Divider: The circuitry of the PERIOD to ANALOG CONVERTOR is designed to accept pulse rates up to a maximum of 450 PPM directly. Pulse rates in excess of this are divided by IC1 to ensure the maximum is never exceeded. Pin 11 and pin 6 are IC1 outputs which are divided by 4 and by 16 respectively. The divide by 2 output, pin 12, is used in conjunction with the START-UP/SHUT DOWN CONDITIONER.

Ramp Sample Timer: The signal from SW1-a is fed to IC3, a dual precision retriggerable multivibrator. The inverted output causes Q7 to conduct, on the low level, applying a voltage to the gate of Q9 which samples the voltage at that instant and holds it. The non-inverted output is fed to the Ramp Reset Timer.

Ramp Reset Timer: The ramp sample timer output IC3-6 changes state on the falling edge of the input signal. IC3 pin 9, inverted output causes Q8 to conduct, on the low level, applying a voltage to the gate of Q10 which resets the ramp generator back to zero volts 30 μS after Q9 has sampled the ramp voltage.

Period to Analog Convertor: The rate of increase of the ramp generator is dependent upon the selection of SW1 (Span, Coarse Adjust) and P1 (Span, Fine Adjust), Q9 samples the voltage level of the ramp and holds it. The sample and reset action occurs at the beginning of each period and takes about 450 μS . Therefore, a voltage proportional to period is produced. The ramp raises its voltage, is measured and stored and quickly reset at the next pulse to start over again.

Analog Divider: The signal voltage is now applied to pin 11 of IC5. Pulse width modulation is used to switch the solid state SPDT switch of IC5. The higher the signal voltage, the narrower the pulse, therefore, Pin 2 of IC5 is switched to Pin 4 a shorter percentage of time. With a lower signal voltage the pulse generated at Pin 9 is wider, in turn Pin 2 is at the 10V level and longer percentage of time. The voltage level at the output of buffer amplifier IC7 is proportional to the ratio of High to Low time of the waveform at Pin 2 of IC5. i.e. if the voltage is High 25% of the time, the voltage level would be 25% of 10V. This voltage level is now proportional to the speed of the monitored device. It is available at 2TB terminals 5 (-) and 6 (+). This 0 to 10V level is converted to a -1V to -5V level which is used by the Satellite Alarm Card and by the LCD Meter, through plug 1RC.

Voltage to Current Convertor: The 0 to 10V signal is also fed through a Voltage Controlled Current Source with an elevated zero output to give a 4 to 20 mA output at 2TB terminals 7(-) and 8 (+). The 4 to 20 mA output can be used with a 0 to 750 ohm load.

Start-Up/Shut Down Conditioner: For start-up, when power is turned on, IC1, 2 and 3 are reset. IC2 Pin 6 is low and Pin 7 is high. The high on Pin 7 switches Q11 ON causing a 0V output at the output terminals. The low at Pin 6 turns Q6 ON which turns Q9 ON. When the second pulse is sensed, IC2 is set. Pin 6 goes high, Pin 7 low, Q9 and Q11 open and regular operation begins. IC2 now waits for a very long lapse in time between probe pulses. Every second pulse sets IC2 but if the period between pulses exceeds 47 seconds, $\pm 10\%$, Pin 2 goes high. This means Pin 6 goes low which turns Q9 ON. Pin 7 goes high, causing Q11 to short C25 to ground, zeroing the output levels to 0V and 4 mA.

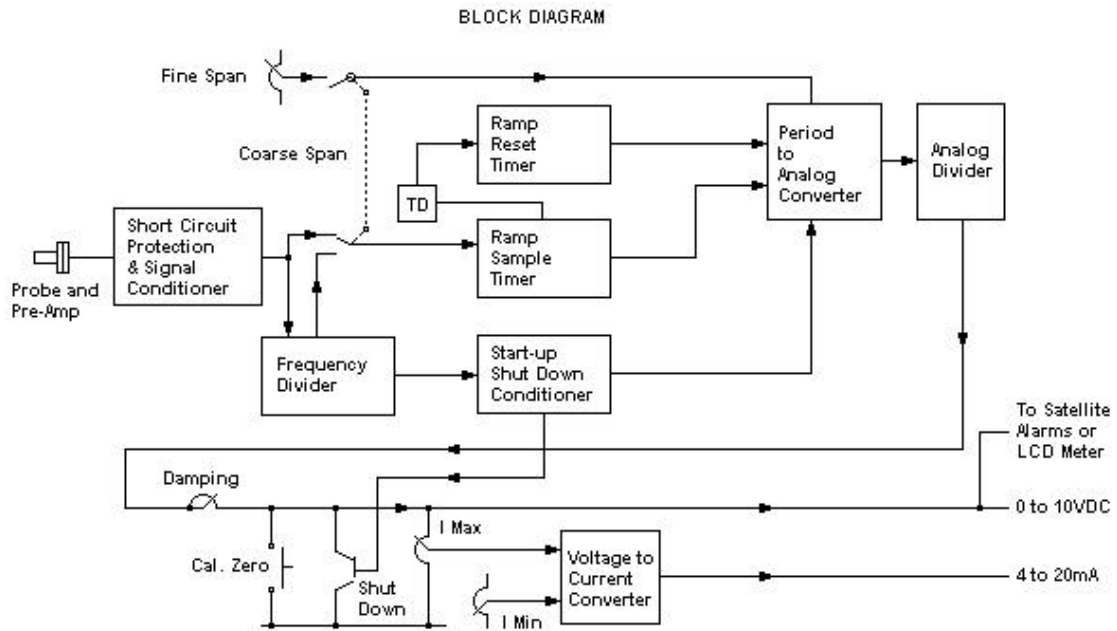

NCT-2 INTERCONNECT

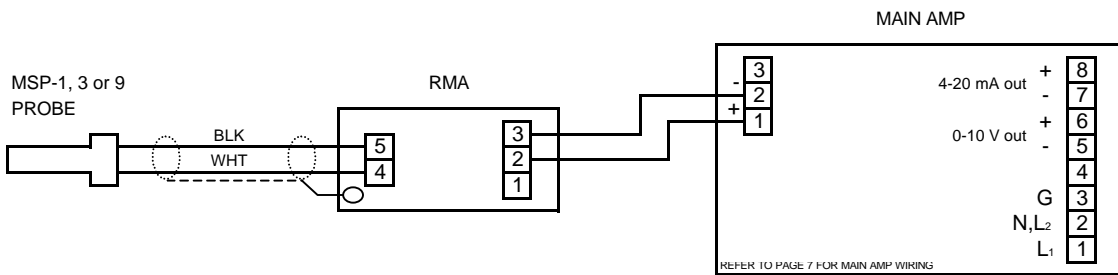

NOTE: Max. cable length from probe to RMA is 100' of shielded cable. 18 ga. Wire.
See table below for cable lengths from RMA to main amp.

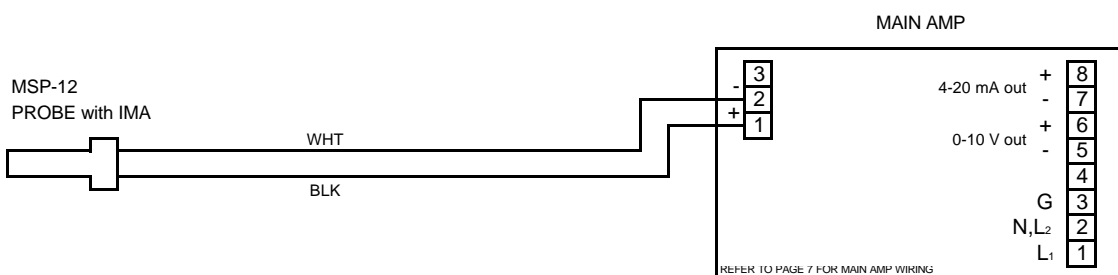

NOTE: Shielded cable not required. Wire can be run in conduit common to motor supply or control wiring. Connection to probe leads can be made under probe cap. See table below for cable lengths from IMA to main amp.

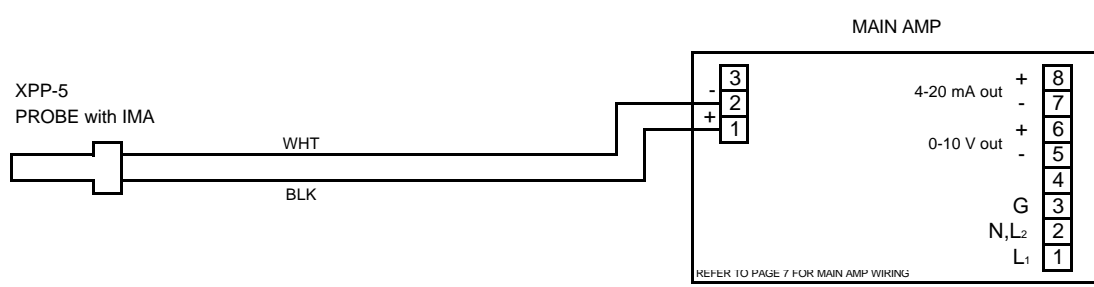

NOTE: Shielded cable not required. Wiring of cable must be done in an approved junction box and to procedures in accordance with all local bylaws, rules & regulations. See table below for cable lengths from IMA to main amp.

MAXIMUM CABLE LENGTH from RMA or IMA to MAIN AMP

Wire Ga.	Max. Length in Feet	Max. Length in Meters
22	2500	760
18	5000	1520
12	25000	7600

ISSUED
DATE
INFORMATION
APPROVED
CERTIFIED

NO	DESCRIPTION	DATE
SCALE	NTS	DATE
DRAWN	WWC	06/10/01
CHECKED	WWC	06/10/01
APPROVED	WWC	06/10/01

TITLE
NCT-2 INTERCONNECTION



FILE 20374301	DRAWING NO.	REV
PLOT 1:1	1-30111Z-DU-B	0
JOB NO.		

External Connections

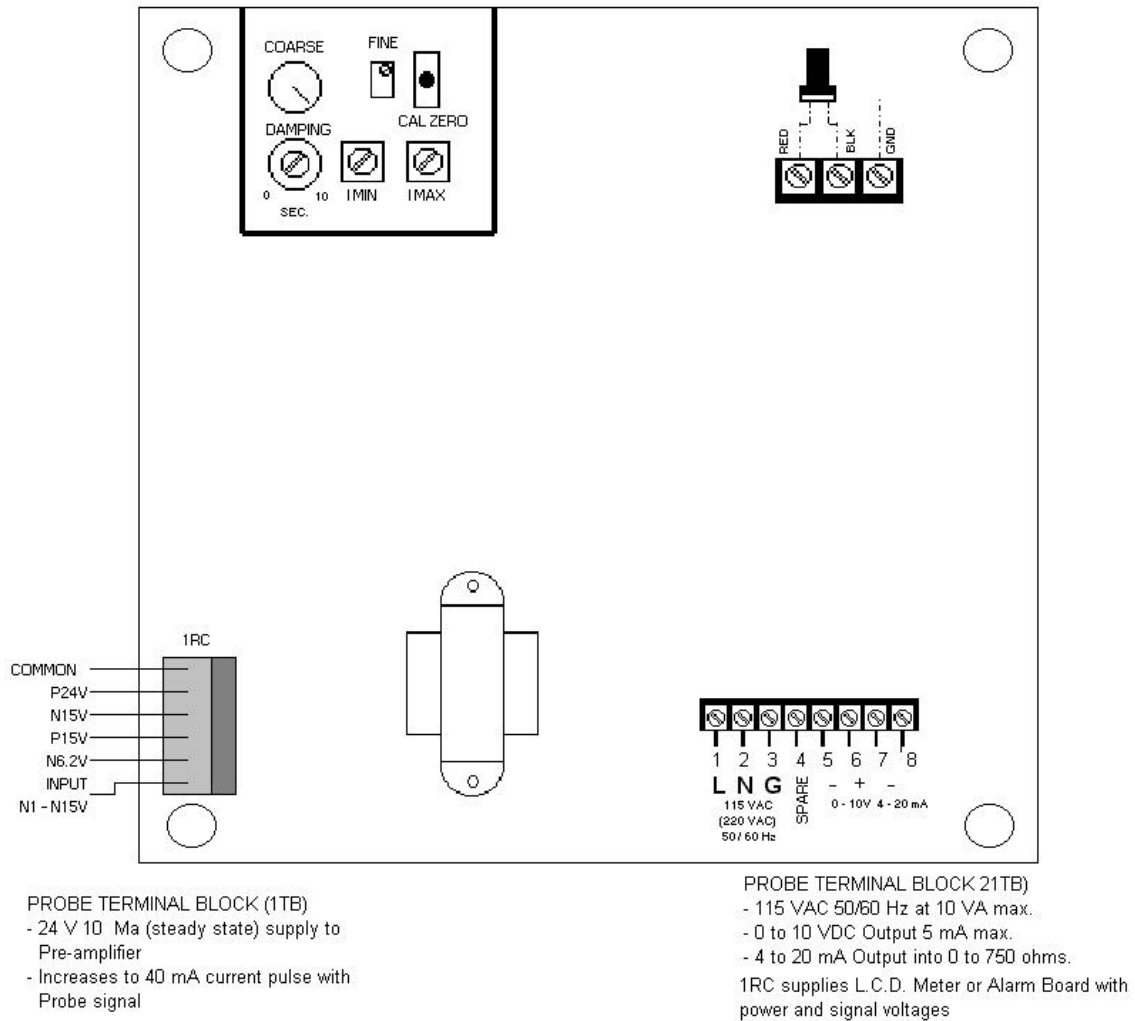

Alarm PCB Terminal Block Connections

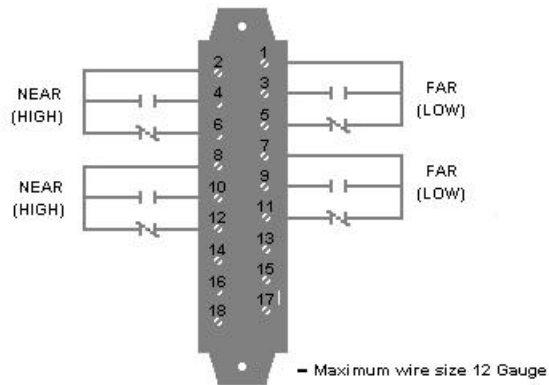

- Notes:**
- Contacts are shown in ALARM condition.
 - Relay de-energized.
 - CSA requires a 10 A or less fuse to protect contacts. For 240 VAC, protect the contacts with a 1500VA transformer as well.

Satellite Alarm Module

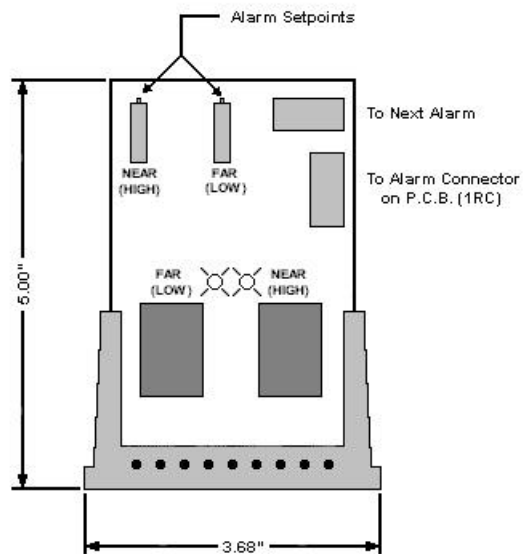

Enclosure Dimensions

Small Enclosure

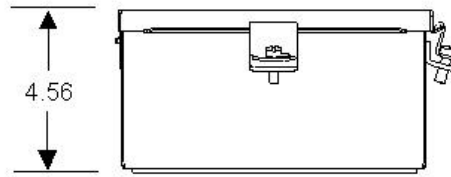
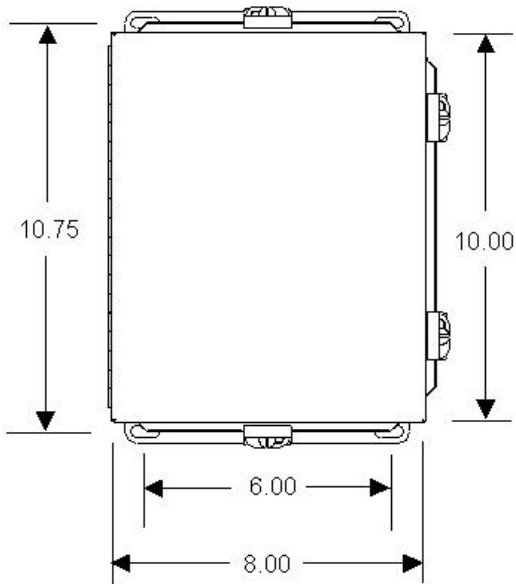

Large Enclosure with Alarms

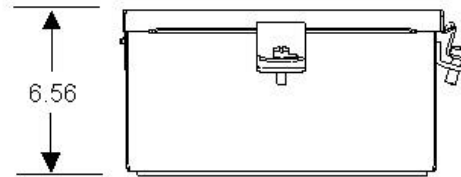
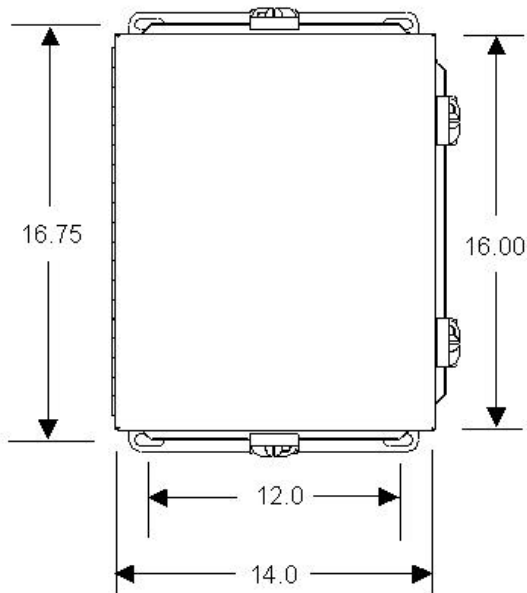

Small Enclosure with Meter

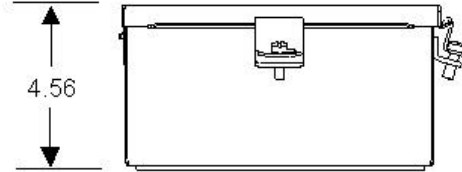
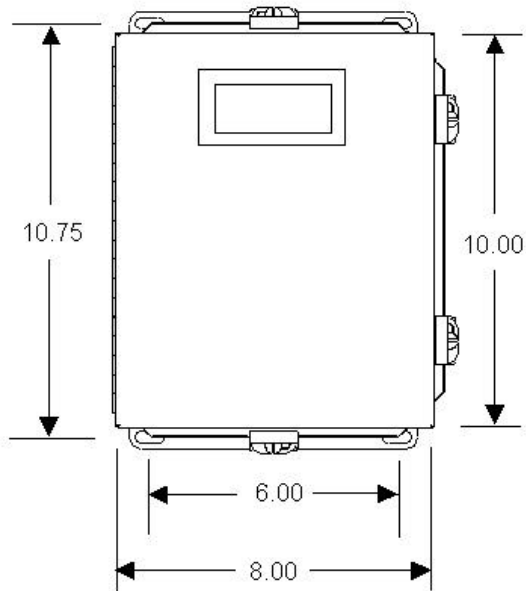

Large Enclosure with Meter and Alarms

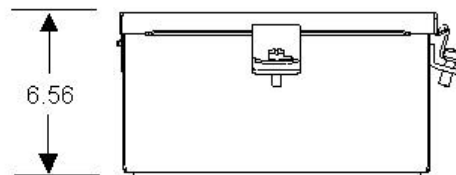
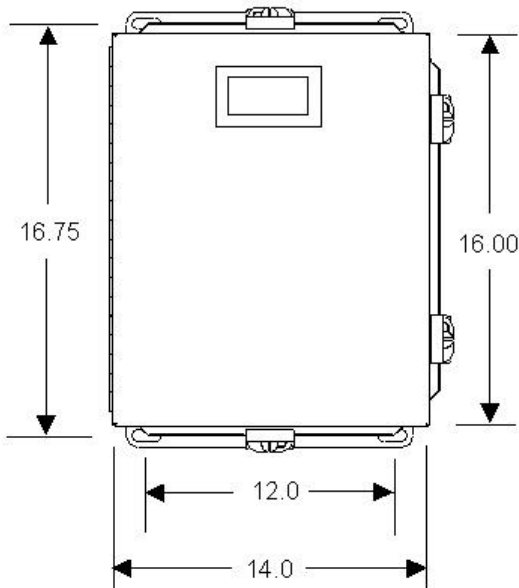

Probes

Mini Sensing Probe MSP-1

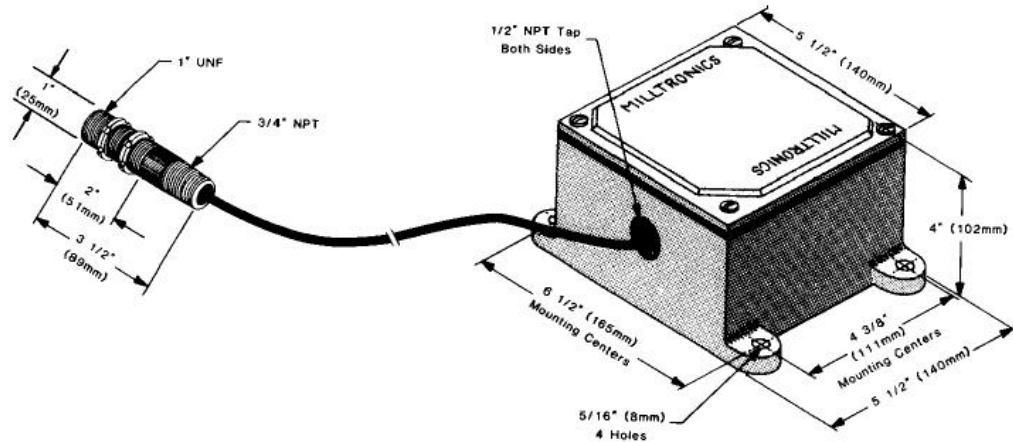

- CPVC body c/w 2 CPVC locknuts
- 6 ft. of Belden 8760 supplied potted in probe
- Remote mounted pre-amp in Nema 4 cast aluminum enclosure.

High Temperatures MSP-3

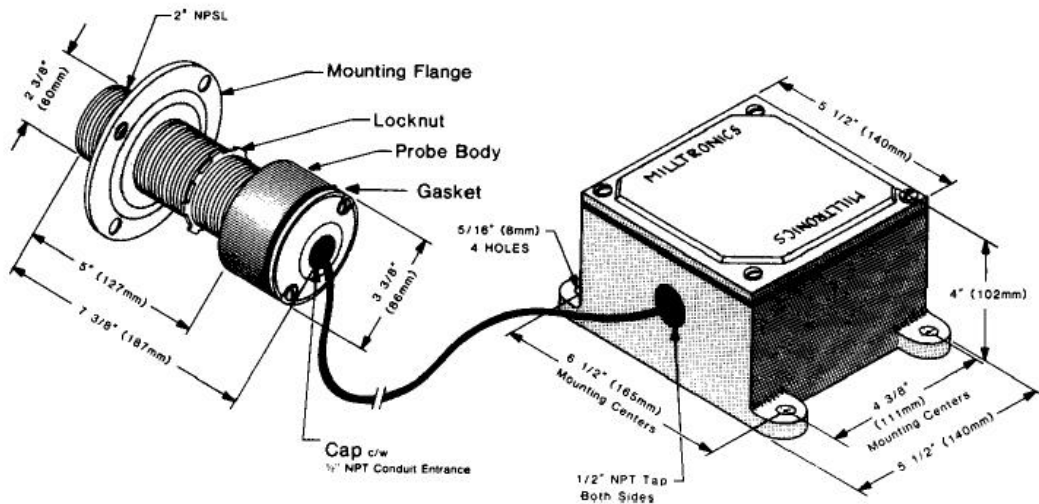

- Cast aluminum body c/w cast aluminum cap and zinc flange, zinc plated locknut, and silicone rubber gasket
- See page 30 for Flange and Mounting Details
- Pre-amp is mounted in a Nema 4 cast aluminum enclosure

Stainless Steel Probe MSP-9

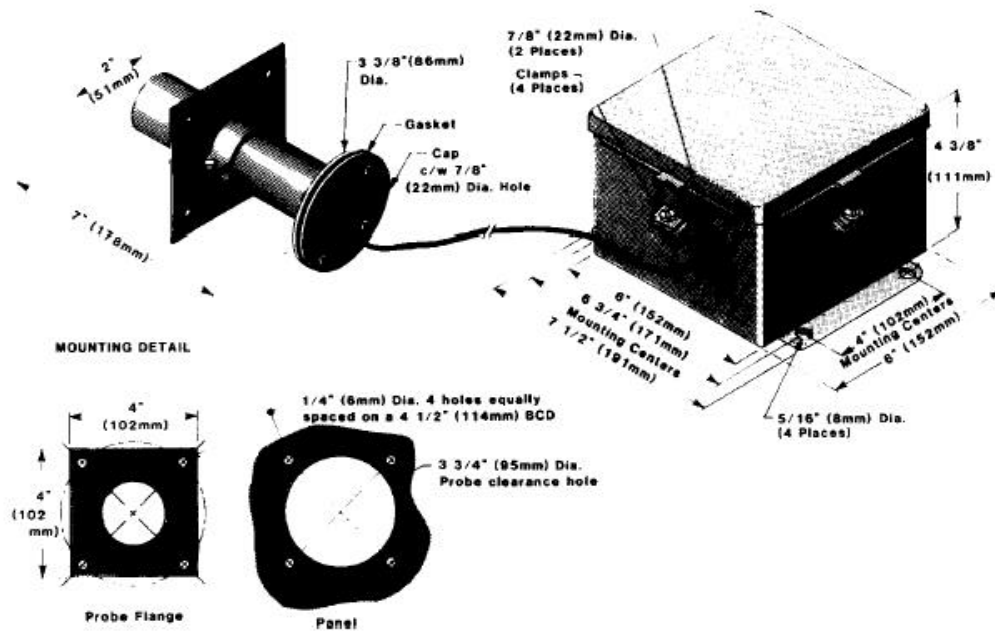

- For high temperature and corrosion resistance applications
- 304 stainless steel body c/w stainless steel clamp and silicone gasket
- 5 ft. Belden 83321 Teflon cable potted in probe
- Pre-amp is mounted in an enamel painted steel Hammond 1414N4E enclosure.

Standard MSP-12

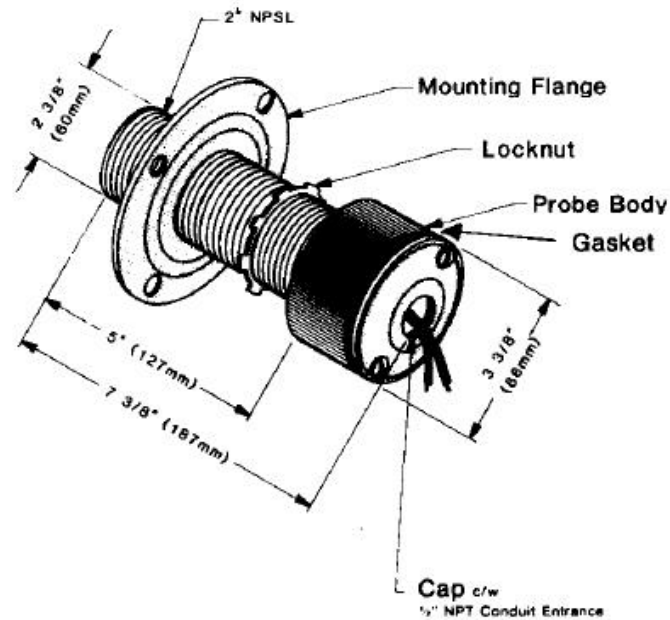

- Phenolic body c/w die cast aluminum cap and zinc flange, zinc plated locknut, and neoprene gasket
- See page 30 for Flange and Mounting Details
- Pre-amp is potted in the probe body c/w two 5" (127 mm) long hook-up wires

Hazardous Locations XPP-5

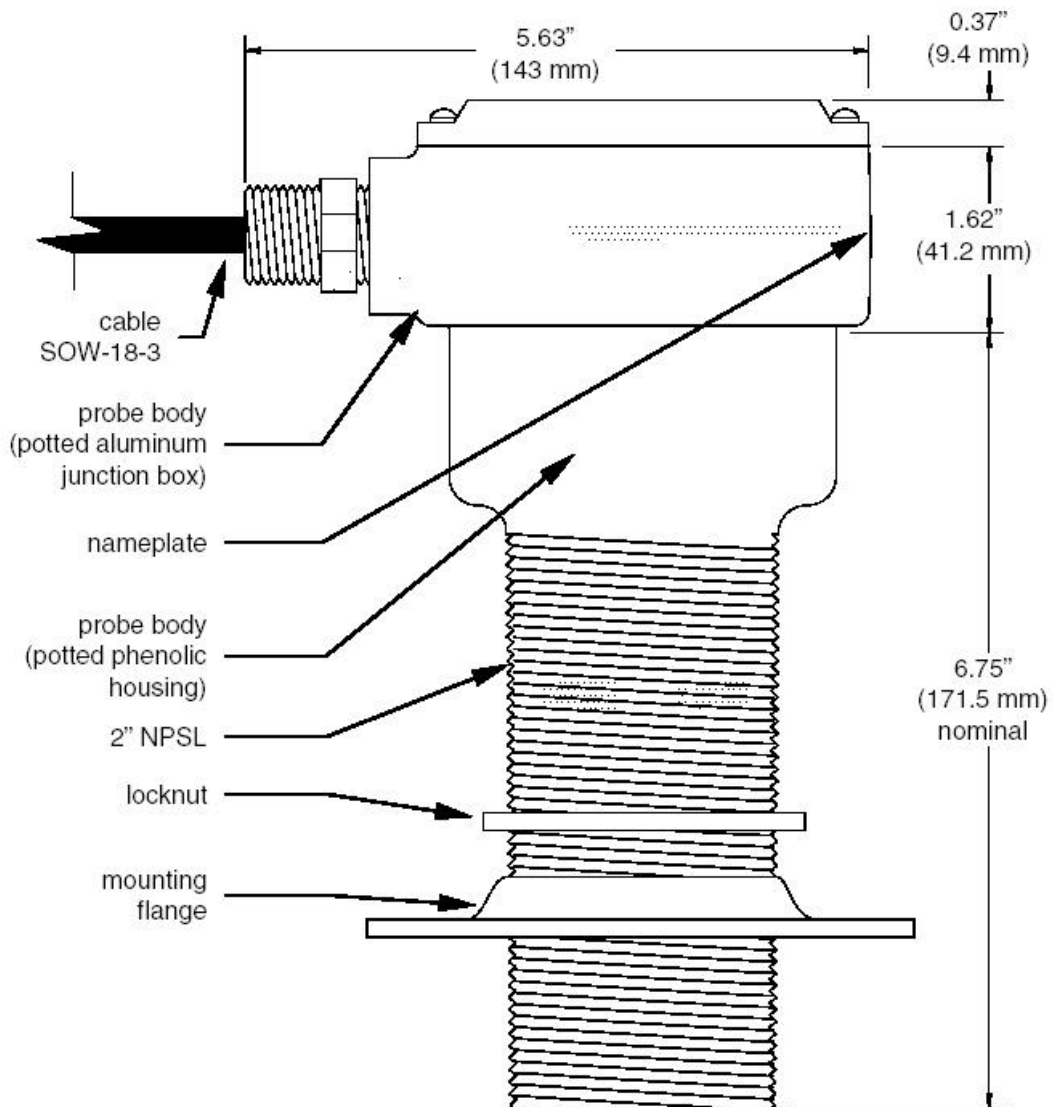

- C.S.A Approved for:
 - Class I, Div.1, Gr. A, B, C & D
 - Class II, Div 1, Gr. E, F & G
 - Class III
- phenolic/aluminum body c/w die cast flange and zinc plated locknut
- see page 30 for mounting details and pages 9 and 29 for interconnection information.
- pre-amp and cable potted in probe body

Mounting Details

Mounting Detail

3.75" (95mm) DIA.
PROBE CLEARANCE
HOLE

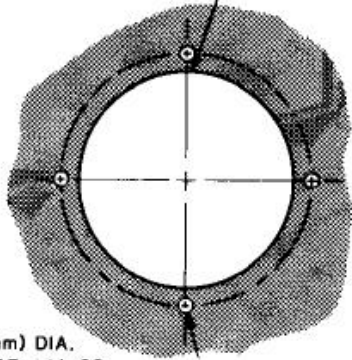

.25" (6mm) DIA.
HOLE FOR 1/4-20
NUT & BOLT OR DRILL
& TAP, 4 HOLES ON
4.5" (114) mm BCD

Mounting Flange

APPLICABLE TO ALL PROBES
EXCEPT MSP-1 & MSP-9

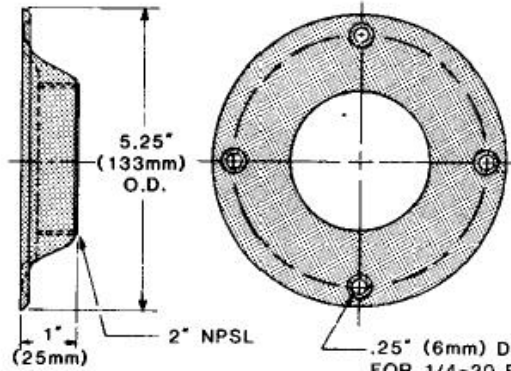

.25" (6mm) DIA. HOLE
FOR 1/4-20 BOLT ON
4.5" (114mm) BCD, 4
PLACES

Applications

Belt Conveyors

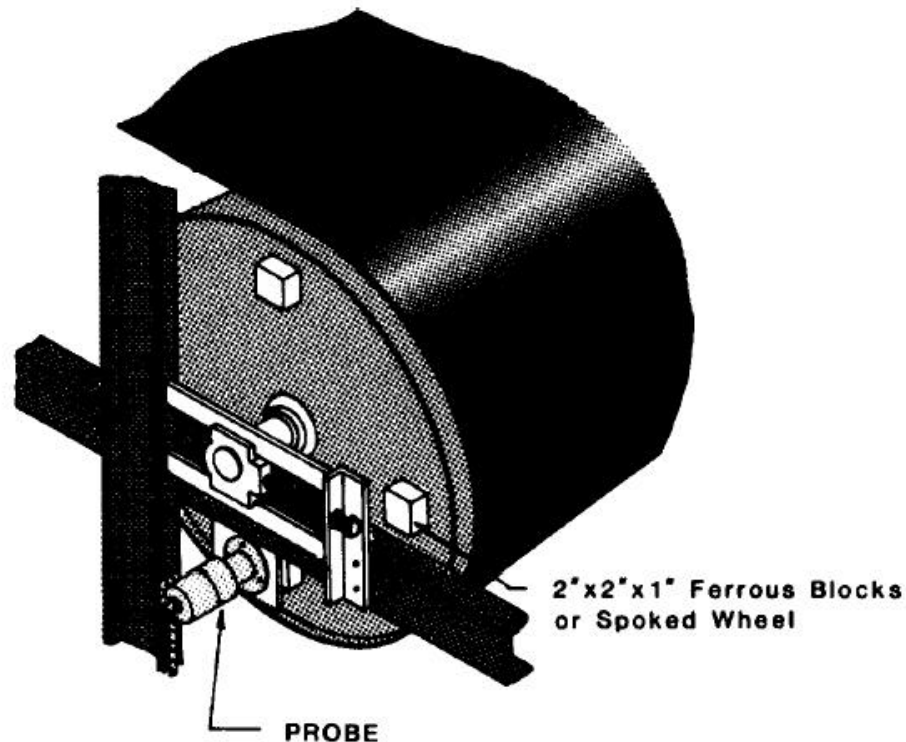

The preferred method for monitoring a belt conveyor is to mount 2" x 2" x 1" (50mm x 50mm x 25mm) ferrous blocks on the driver pulley. The blocks must be equally spaced as to assure a uniform pulse rate.

The number of blocks depends on the resolution required. If the signal from the probe is used to indicate the speed of a slow moving device, the number of blocks should be increased. This will give a steady meter reading, rather than have the needle bounce.

The maximum gap between the probe and block is dependent on the speed of the conveyor, the minimum gap allowable is governed by the potential for damage in each application.

Screw Conveyors

Secondary choice because of restricted maintenance procedure on screw conveyor.

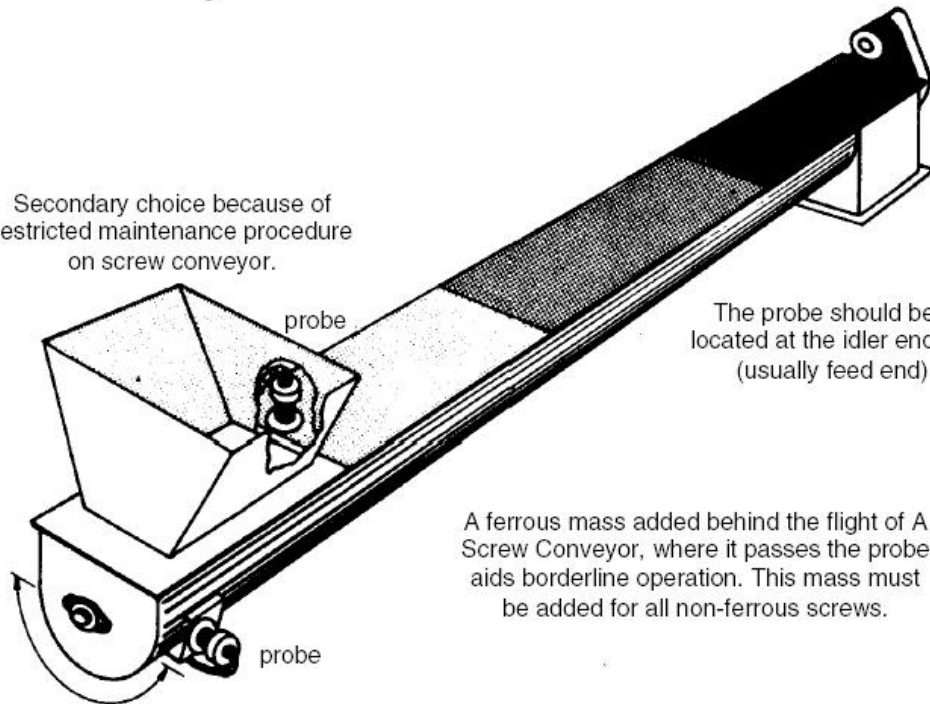

The probe should be located at the idler end (usually feed end).

A ferrous mass added behind the flight of A Screw Conveyor, where it passes the probe aids borderline operation. This mass must be added for all non-ferrous screws.

Arrows indicate permissible placement range of the probe.

For Screw Conveyors with the trough over 0.1" thick, or for high temperature applications, a non-ferrous 'window' allows monitoring of the screw flight. Use Stainless Steel, Brass or Aluminum for the window and the bracket. The Standard Probe may touch the window unless temperatures are in excess of 140°F (60°C), for high temperature applications the MSP-9 probe can be used, 500°F (260°C). An air gap will allow a higher temperature than specified.

Non-Ferrous Window

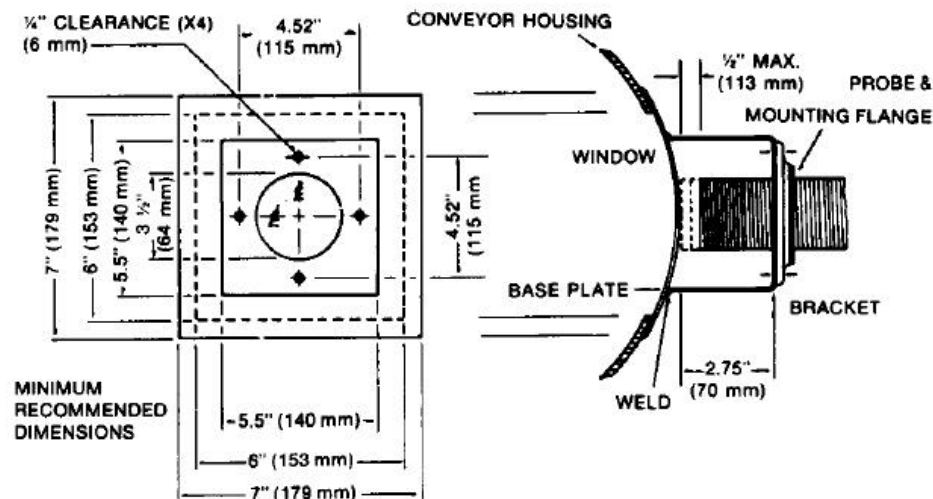

Shafts

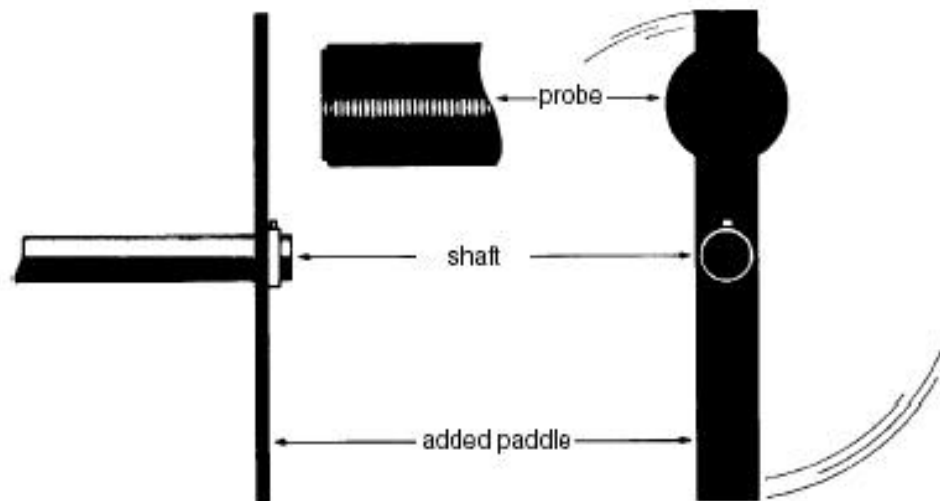

Safety shield not shown

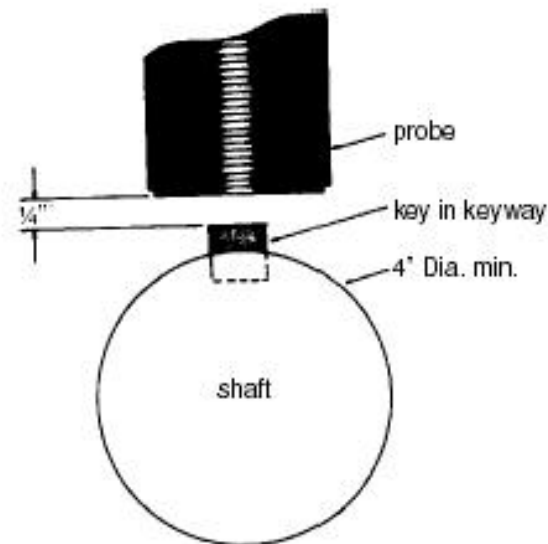

Shafts in excess of 4" (102mm) in diameter may be sensed on the key.

Where conditions prevent the sensing of the actual equipment, the addition of a belt pulley or paddle mounted on an exposed shaft can be sensed.

These methods are viable if the speed is such that the minimum velocity is greater than 5 ft./min. (1.5m/min). In applications where exposed moving parts are required, safety shields and precautions should be applied.

Drag Conveyors

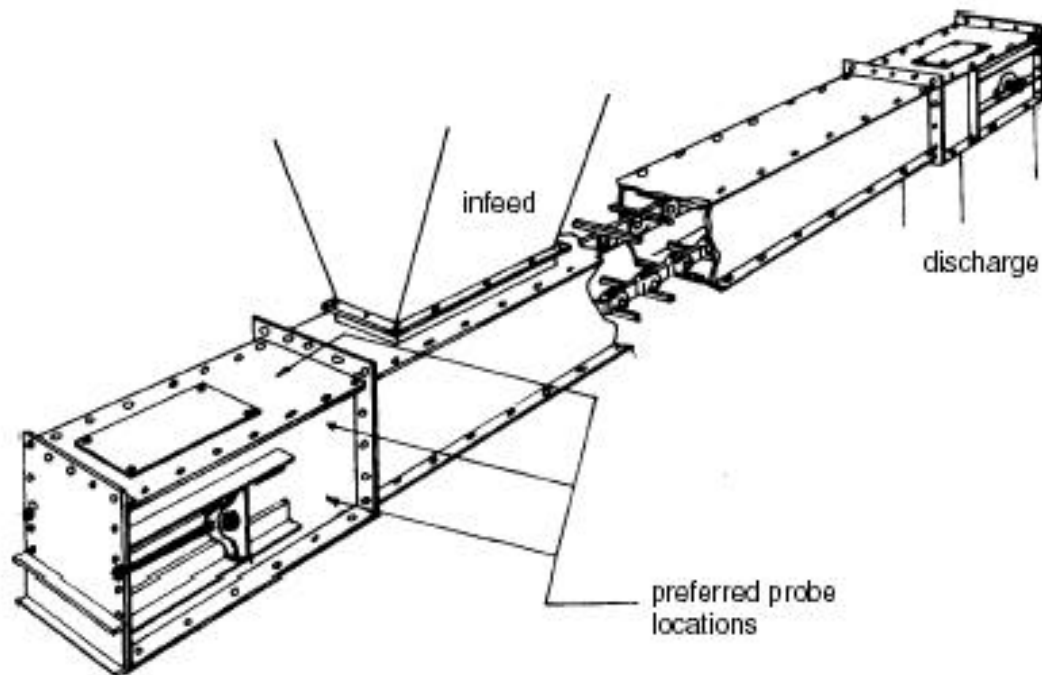

The Probe is mounted to monitor the T flight of the drag conveyor. The Probe should be mounted at the point of minimal vertical deflection, so as to avoid double pulsing, and where experience shows breakage occurs more often.

The T flight can be monitored from the side, if greater than 112" square, but it is preferred to be monitored from above or below. The distance between two T's must be 3" or greater for the Probe to distinguish between the two bars. The preferred location for the Probe is at the take-up end of the conveyor.

When the Probe cannot protrude through the enclosure a non-ferrous 'window' can be incorporated, as illustrated for a screw conveyor.

If the T flight cannot be monitored the shaft of the take-up should be monitored.